

Satellite RFI mitigation on FAST

Yu Wang^{1,2,3}, Hai-Yan Zhang^{2,3}, Hao Hu², Shi-Jie Huang², Wei-Wei Zhu^{2,3}, Guo-Ping Zhi⁴, Tao Zhang⁴, Zhan-Chun Fan⁴ and Li Yang^{2,3}

¹ University of Chinese Academy of Sciences, Beijing 100049, China; wangy@nao.cas.cn

² National Astronomical Observatories, Chinese Academy of Sciences, Beijing 100101, China

³ CAS Key Laboratory of FAST, National Astronomical Observatories, Chinese Academy of Sciences, Beijing 100101, China

⁴ Beijing Institute of Spacecraft System Engineering, Beijing 100094, China

Received 2020 April 29; accepted 2020 July 19

Abstract As the most sensitive single-dish radio telescope, the Five-hundred Aperture Spherical radio Telescope (FAST) is very susceptible to radio frequency interference (RFI) from active radio services. Moreover, due to the rapid development of space applications and research, satellite interference has become one of the main RFI sources for FAST, particularly at the L band. Therefore, we have developed several measures to mitigate satellite RFI. On the one hand, an antenna with 4.5-meter diameter has been constructed and installed at the FAST site to detect the satellite interference in the frequency band between 1 to 5 GHz. Meanwhile, we have developed a satellite RFI database based on the FAST sky coverage, the observing frequency bands, and known satellite systems. By combining the satellite RFI monitoring antenna and the database, we have established a satellite RFI mitigation system. With this system, we can not only track satellites to collect their characteristics and update the database but also help the observer to program the observing plan by predicting satellite interference. During the practical observation of FAST at the L band, the feasibility of this system to mitigate satellite RFI has been proved. In particular, the system effectively avoids strong satellite interference from entering the main beam of the telescope and causing receiver saturation.

Key words: telescopes: FAST — satellite radio frequency interference — mitigation

1 INTRODUCTION

Due to the rapid development of active radio services, the radio astronomy service (RAS) is more vulnerable to radio frequency interference (RFI) from active services. For the Five-hundred-meter Aperture Spherical radio Telescope (FAST) (Nan et al. 2016; Peng et al. 2004), the main challenges of RFI mitigation are caused by the high sensitivity of the telescope in the bands of 70–3000 MHz, the complex system of the telescope and the deteriorating radio environment. Thanks to the radio quiet zones around FAST (Zhang et al. 2014) and measures of Electromagnetic Compatibility (EMC) (Zhang et al. 2016, 2018a,b), RFI from terrestrial transmitters and the telescope itself have been mitigated effectively.

Nevertheless, there are thousands of artificial satellites revolving around the earth. Depending on the purpose, the satellite is placed into a certain orbit around the earth, and certain frequency bands are allotted to it

by International Telecommunication Union (ITU). For instance, BeiDou Navigation Satellite System (BDS) includes several Geostationary Orbit (GEO), Inclined Geosynchronous Orbit (IGSO), and Middle Earth Orbit (MEO) satellites. Besides, the center frequencies consist of 1561.098, 1207.140, and 1268.520 MHz, etc¹. Since the satellite communication shares the frequency band with the RAS and can hardly be avoided by radio quiet zones, it becomes more difficult to be mitigated. According to the current observations, satellites have become one of the main RFI sources for FAST, especially at L bands. As the key receiver of FAST, the 19-beam receiver is used to observe the main scientific objectives of FAST including HI and pulsars in the band between 1.05 and 1.45 GHz (Jiang et al. 2020). During the observation, the most detected RFI is from the radio positioning satellite systems, such as BDS, the Global Positioning System

¹ <http://www.csno-tarc.cn/system/introduction>

Table 1 Lists of Satellite Systems that Might Affect the FAST 19-beam Receiver

No.	Frequency (MHz)	Satellite System
1	1176.45±1.023	GPS, Galileo
2	1207.14±2.046	BDS, Galileo
3	1227.6±10	GPS
4	1246.0–1256.5	GLONASS
5	1268.52±10.23	BDS
6	1381.05±1.023	GPS
7	1467–1492	AsiaStar

(GPS), and broadcast satellite systems, such as AsiaStar. The main satellite systems that might affect FAST’s 19-beam receiver have been listed in Table 1. Figure 1 shows the time-frequency plane and spectrogram from the center beam of the 19-beam receiver on 2020 February 14. The RFI from satellites can be detected clearly. In some cases, strong RFI can cause data overflow or even receiver saturation.

In general, satellite RFI has always been labeled and mitigated during post-correlation processing (An *et al.* 2017; Fridman & Baan 2001). Data from bands contaminated by strong satellite RFI would be discarded during processing, in this way all scientific data in that band would be eliminated at the same time. It may reduce the observation efficiency of the telescope and shorten the life of the receiver. In order to mitigate the RFI from satellites for FAST in a better way, we established a satellite RFI mitigation system including a monitoring system and a satellite database at the FAST site. The study on a similar system is ongoing at the Giant Metrewave Radio Telescope (GMRT) (Katore *et al.* 2019). Using this satellite RFI mitigation system, it becomes possible for FAST to monitor RFI from the satellites, warn the potential RFI based on the observation schedule, and avoid the strong satellite RFI during observations effectively. More details about the satellite RFI monitoring system, database, and mitigation strategy are presented in the following sections.

2 SATELLITE RFI MONITORING SYSTEM

To track the satellites in FAST sky coverage, a satellite RFI monitoring system in the frequency band between 1 to 5 GHz has been constructed and installed at the FAST site. Figures 2 and 3 show a block diagram and photos of the system, respectively, it can be seen that the monitoring system mainly consists of a 4.5 m antenna, a control system, and a spectrum analyzer.

The antenna uses an X-Y style mount and the rotation range of each axis is from -90° to 90° . Compared with

Table 2 The Technical Specifications of the 4.5 m Antenna

No.	Specification	Value
1	Frequency range	1 GHz~5 GHz
2	Antenna gain	>30 dBi
3	Gain (LNA)	>20 dBi
4	Focus ratio	$F/D = 0.4$
5	System temperature	<300 K
6	Tracking accuracy	$\leq 0.2^\circ$
7	Pointing accuracy	$\leq 0.1^\circ$
8	Angle measurement accuracy	$\leq 0.1^\circ$
9	Rotation speed	$0.01 \sim 5^\circ \text{ s}^{-1}$
10	Max rotational acceleration	5° s^{-2}

the traditional alt-azimuth antenna, the antenna with X-Y style does not have the blind zone at the zenith. Due to this advantage, this antenna is more suitable for satellite tracking tasks, especially when the satellite is located near the zenith (Li & Jia 2014). Moreover, the receiver of the antenna is capable of dual circularly polarized signals and can realize real-time switching. Further technical specifications of the antenna are presented in Table 2.

In May 2019, this antenna was installed at the FAST site. The EMC performance has also been tested and met the specifications in 1–5 GHz band. Nowadays, with the monitoring system, the satellite can be tracked and monitored. Figure 4 shows the measurement results of the satellite RFI by using this antenna in the 1–1.5 GHz band on 2019 August 22. Compared with Figure 1, the main RFI from the satellite systems such as GPS, BDS, and AsiaStar is detected clearly.

3 SATELLITE RFI DATABASE

Based on the FAST sky coverage, the observing frequency bands, known satellite systems such as GPS, BDS, etc., and the practical satellite RFI measurement results, a satellite RFI database for FAST has been developed which consists of the satellite information and observation modules. Figure 5 shows a schematic illustration of the database, and the function of each module is described in this section.

The satellite information module mainly contains two parts. The first part is the basic information table including basic information about satellites such as their official name, international number, type, weight, period, inclination, orbital parameters (two Line Elements, TLEs) table, etc. This information is updated via websites or user import and provides the parameters for predicting satellite orbits (Li & Yu 2016). The second part is the frequency-power level table. It contains the frequency band and the power level of the satellite. This table is used to estimate the level of satellites’ impact. Due to the complexity of the satellites with various technical characteristics, the angular distance has been chosen to assess whether a satellite is a threat to the observation of FAST. Currently, considering the main beamwidth of FAST (about $27'$ at the L band with

² All three signals in the figure were detected during the prediction period, which correspond to the multi-band signals (1207.14, 1268.52 and 1561.098 MHz) of BeiDou 5 satellite.

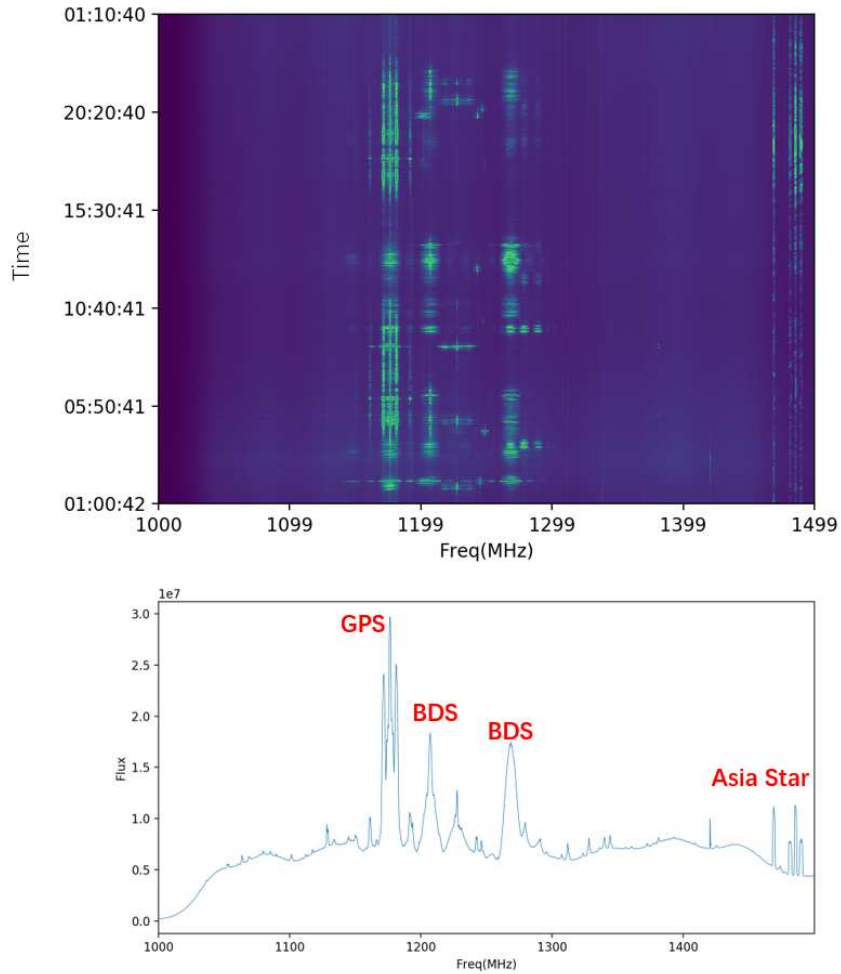

Fig. 1 The time-frequency plane (*top*) and the spectrogram (*bottom*) of FAST observation on 2020 February 14.

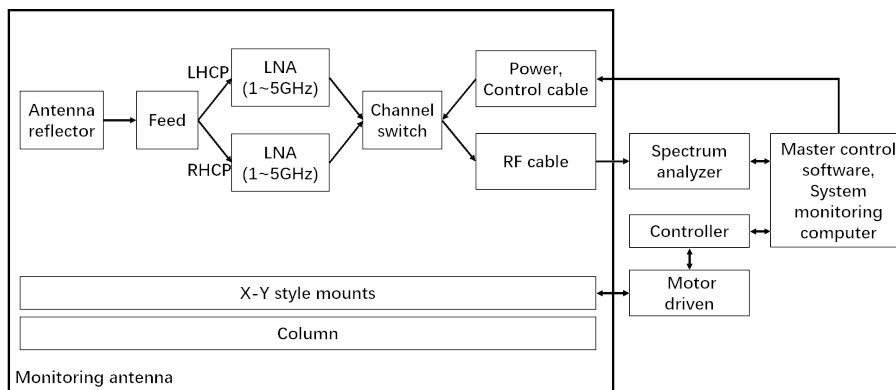

Fig. 2 The block diagram of the satellite RFI monitoring system.

the 19-beam receiver) and practical observations, three levels of RFI influence of the satellite have been identified. The satellite with an angular distance of less 1° from the main beam of FAST is marked as a danger RFI source, the satellite with an angular distance between 1 and 2°

is marked as an RFI source requiring attention, and the satellite with an angular distance larger than 2° is marked as an ordinary RFI source.

The function of the observation module is to calculate the angular distance of satellites based on the observation

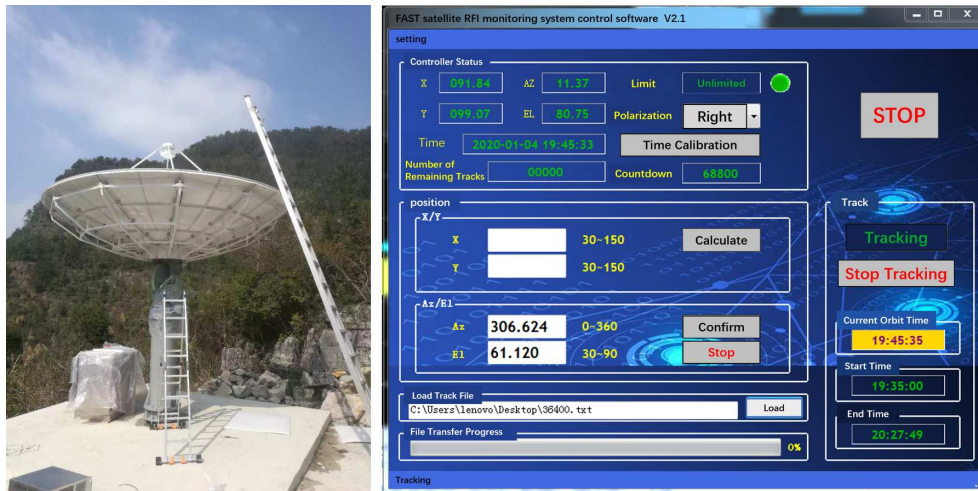

Fig. 3 The photos of the 4.5m antenna (left) and the interface of the control system (right).

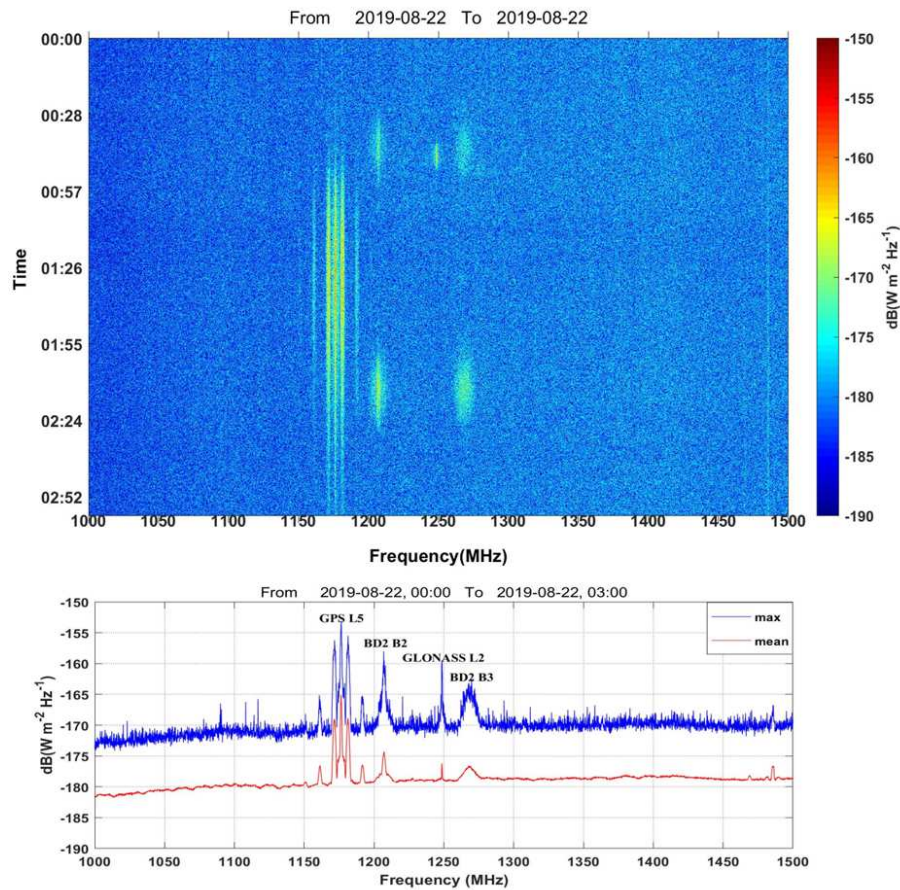

Fig. 4 The RFI measurement results by using the 4.5 m antenna on 2019 August 22. Time-frequency plane (top), spectrogram (bottom).

schedule. After uploading the planning period and observation proposals which include the beam parameters, observation frequency band and source information, etc., the module can calculate the pointing of the main beam during the observation. Meanwhile, the orbital parameters

of the satellites operating in the observation band are obtained from the basic information table and imported to calculate the satellite's orbit during the observation period automatically. The angular distances between the satellites and the main beam of FAST are estimated and the

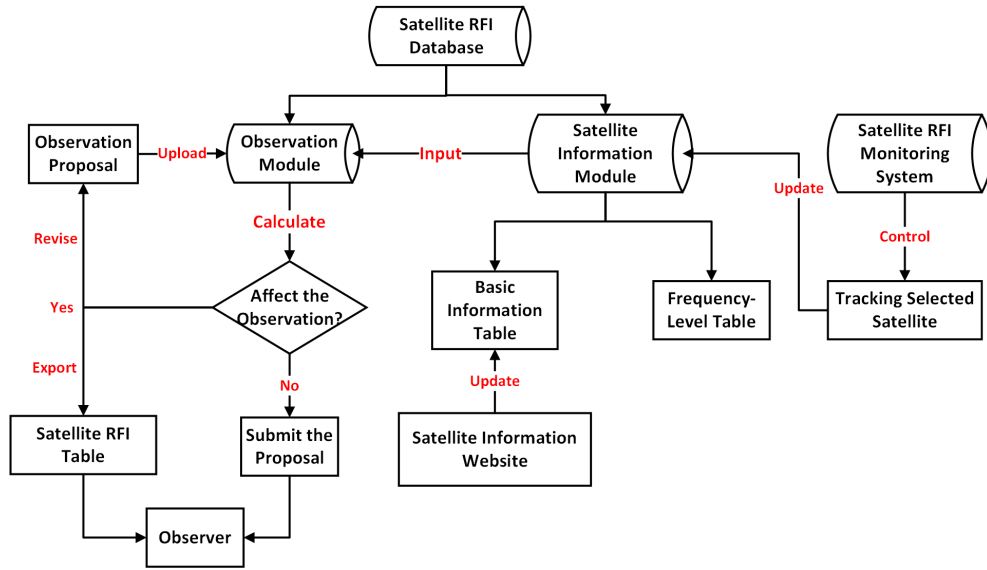

Fig. 5 The schematic illustration of the satellite RFI database.

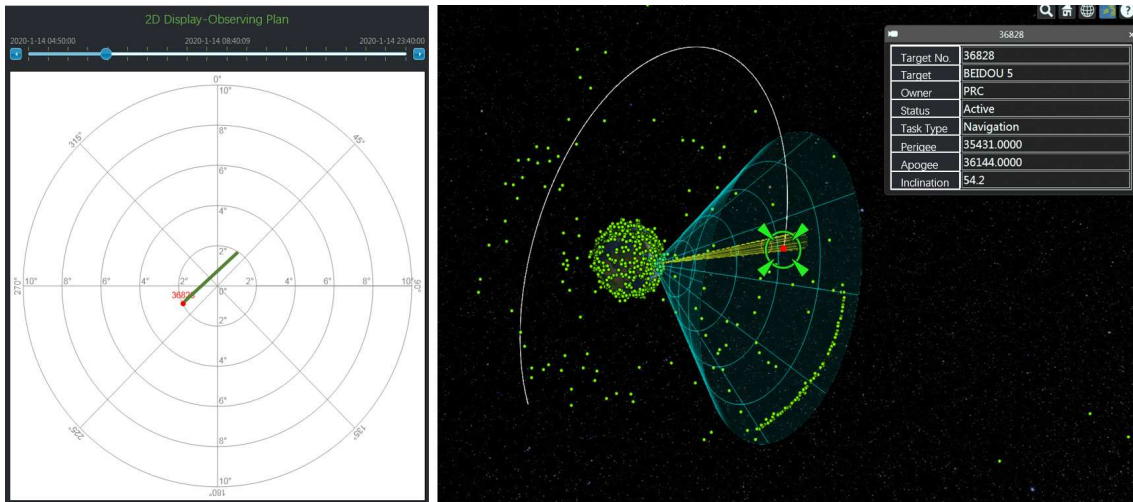

Fig. 6 The predicted orbit of BeiDou 5 satellite on 2020 January 14. 2D (left): the red point corresponds to the satellite and the green line shows the satellite’s orbit within 2° of the beam center; 3D (right): the white curve represents the orbit of the satellite, the smaller conical surface represents the 2° range from the beam center, and the larger conical surface represents the field of view.

satellites that might affect the observation of FAST could be predicted. As a result, a satellite RFI table is exported which consists of the transit time, frequency band, and power level of satellites. Besides, it supports 2- and 3-dimensional display of the satellite orbit passing the main beam of the telescope for more visible information.

Meanwhile, the basic information of the satellites can be updated by the measurement results from the satellite monitoring system. Also, the satellite orbit file from the database can be imported into the control software of the monitoring antenna for tracking mission. Using the database, the proposal can be revised to avoid the strong satellite RFI, also it provides a basis for subsequent RFI

removal. In the next section, we discuss a satellite RFI mitigation strategy based on this monitoring system.

4 SATELLITE RFI MITIGATION

As mentioned above, using the satellite RFI mitigation system including the satellite RFI monitoring antenna and database, we can not only track the satellite to obtain its characteristics but also assess the effect of satellite RFI on the observation and export the satellite RFI table to detect the strong satellite RFI. In this section, the satellite RFI mitigation strategy is described, and an example is also given to show the accuracy and effectiveness of the system.

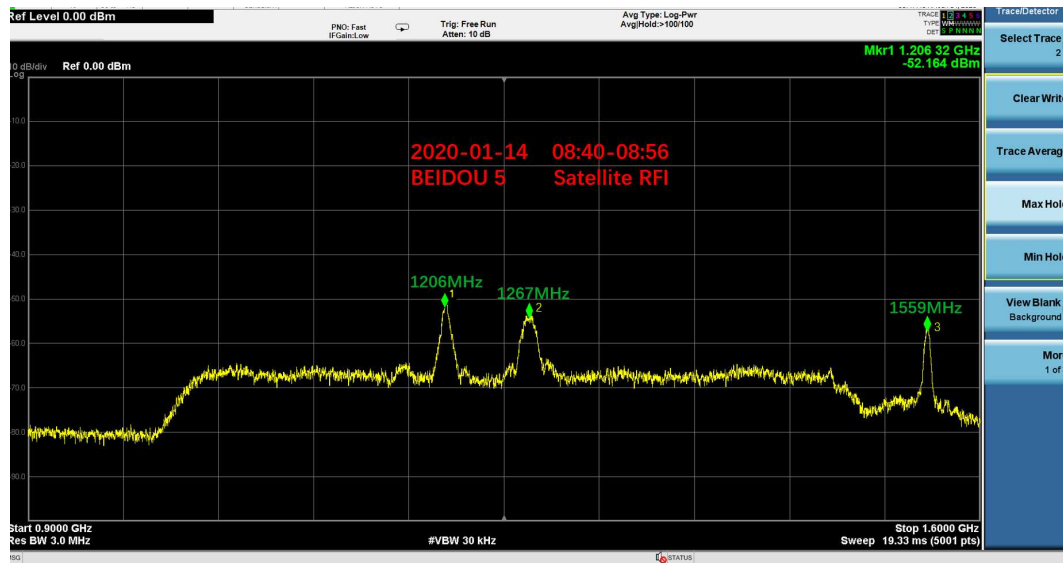

Fig. 7 The spectrogram of the BeiDou 5 detected by the spectrum analyzer connected to the telescope during the predicted time period on 2020 January 14².

For satellite tracking missions, the purpose is to detect the characteristics of the satellite and update the basic information table for subsequent RFI evaluation. Before tracking, the monitoring period needs to be set up and the satellites falling in the sky coverage of FAST during the period can be obtained. Then, users are required to select the satellite they wish to track and export the orbit file. After that, the orbit file is uploaded in the antenna control software, and monitoring results can be stored for subsequent processing and evaluation. Moreover, the real-time display of the satellite signal is supported by the spectrum analyzer connected to the monitoring antenna.

The strategy of proposal planning can be divided into the following steps: (1) the operator uploads the proposal to the observation module and set up the period; (2) our system can automatically calculate the pointing of the main beam during the period and predict the orbit of satellites working in the observation frequency band by using the orbital parameters in the basic information table; (3) satellites that would affect the observation can be marked and the period falling on the main beam within 2° of the telescope also can be obtained. With the predicted satellite RFI table, it is possible to reschedule the proposal, shuffle the observing sequence of sources or adjust the observing band to avoid satellite interference. On the other hand, we can provide the prediction table to the observer to pay more attention when those satellites arrive. Moreover, observing a different source at a different frequency during satellite passage is also an effective way to avoid data loss. The dynamic observation mode of FAST is planning to minimize the data loss or loss of observing time during this passage. In general, the feasibility of this system has

been proved during the practical observation of FAST. An example of the application of this system is described below.

On 2020 January 14, an observation was scheduled in tracking mode. After uploading the observation plan into the database, eight satellites that might pass the sky within the angular distance of 2° to the main beam of the telescope were marked. The smallest angular distance of about 0.6° between one satellite (BeiDou 5) and the main beam of FAST in 2- and 3-dimensional figures are shown in Figure 6. During the practical observation, signals from BeiDou 5 were detected by the telescope during the predicted period. Figure 7 gives the spectrogram of BeiDou 5 detected by the spectrum analyzer connected to the telescope. According to our experimental results, it shows that our system can accurately predict the satellite orbit and the transit period. With the predicted results, we could reschedule our observing plan or give observers some tips in advance. In this way, the strong satellite RFI can be avoided conveniently to protect the receiver from saturation and improve observation efficiency.

5 CONCLUSION AND PERSPECTIVES

In conclusion, we have now established a satellite RFI mitigation system including a monitoring antenna and satellite RFI database for FAST. Based on the practical results of satellite RFI, we can obtain the satellite RFI characteristics and update the database. Moreover, this system helps us to predict the satellites that threaten an observation and program the observation plan. The reliability of the system has been proved during the practical observations. Particularly, it works efficiently to

avoid strong satellite interference into the main beam of the telescope.

Nowadays, more satellite systems are coming online with large numbers of satellites, and some satellite systems will always have satellites above the horizon of FAST. It would be difficult to avoid all of them. For future work, we need to find better strategies to minimize the data loss or loss of observing time during satellite passages. For instance, our monitoring system will be operated synchronously with the telescope. Based on the monitoring and observing data, we can update our RFI database and improve the reliability of the satellite RFI mitigation system. Besides, the dynamic observation mode of the telescope is planning to decrease the data loss or loss of observing time. In addition, based on the Artificial Intelligence (AI) and Field Programmable Gate Array (FPGA) technology (Finger et al. 2018), fitting a good parametric model of the satellite signal is being developed to mitigate the satellite RFI of FAST more efficiently.

Acknowledgements This work is supported by the Strategic Priority Research Program of the Chinese Academy of Sciences (Grant No. XDB23000000), the National Key Research and Development Program (No. 2019YFB1312704), the National Natural Science Foundation of China (Program No. U1831128) and the International Partnership Program of Chinese Academy of Sciences (Program No. 114A11KYSB20160008). This work is also supported by the National Development and Reform Commission, the Key Laboratory of FAST of CAS. The authors appreciate the hard work made by the EMC group of FAST.

References

- An, T., Chen, X., Prashanth, M., et al. 2017, *Astronomica Sinica*, 58, 43
- Finger, R., Curotto, F., Fuentes, R., et al. 2018, *PASP*, 130, 025002
- Fridman, P. A., & Baan, W. A. 2001, *A&A*, 378, 327
- Jiang, P., Tang, N. Y., Hou, L. G., et al. *RAA (Research in Astronomy and Astrophysics)*, 2020, 20, 64
- Katore, S. N., Gupta, Y., Nayak, S., et al. 2017, 32nd URSI GASS, 19-26 Aug. 2017, [http://www.ursi.org/proceedings/procGA17/papers/Paper_EFGHJ2-6\(1877\).pdf](http://www.ursi.org/proceedings/procGA17/papers/Paper_EFGHJ2-6(1877).pdf)
- Li, D., & Yu, Y. 2016, *Optics and Precision Engineering*, 2016, 24, 2540 (in Chinese)
- Li, J. J., & Jia, Y. H. 2014, *Electro - Mechanical Engineering (in Chinese)*, 2014, 30, 37
- Nan, R. D., Zhang, H. Y., Zhang, Y., Yang, L., et al. 2016, *AcASn*, 57, 623
- Peng, B., Sun, J. M., Zhang, H. Y., Piao, T. Y., et al. 2004, *Experimental Astronomy*, 17, 423
- Zhang, H. Y., Chen, Z. J., Li, B., et al. 2014, XXXIth URSI General Assembly and Scientific Symposium (URSI GASS), 1
- Zhang, H. Y., Nan, R. D., Gan, H. Q., et al. 2016, URSI Asia-Pacific Radio Science Conference (URSI AP-RASC), 1
- Zhang, H. Y., Yao, R., Hu, H., & Huang, S. J. 2018, *IEEE Global Conference on Signal and Information Processing*, 1091
- Zhang, H. Y., Wu, M. C., Yue, Y. L., Gan, H. Q., et al. 2018, *RAA (Research in Astronomy and Astrophysics)*, 18, 48